

THE EFFECT OF INTERNSHIPS AND WORK MOTIVATION ON COLLEGE STUDENTS' WORK READINESS

Ryan Pradipta Setiawan^{1*}, Christian Wiradendi Wolor², Susan Febriantina³

¹⁻³ Faculty of Economics, Universitas Negeri Jakarta, Indonesia

E-mail: ¹⁾ ryanpradipta691@gmail.com

ABSTRACT

Work readiness is one of the main assets that students must have before entering the world of work. The purpose of this study was to determine the effect of internships and work motivation on the work readiness of students of the Economics and Administration Education Study Program at State University of Jakarta. The research method that researchers use in this study is a survey method with a quantitative approach. The population in this study were all active students of the Economics and Administration Study Program at State University of Jakarta, totaling 1,634 students and the affordable population was 318 students. The sampling technique used proportionate stratified random sampling using the Slovin formula with a margin of error of 10% so that the sample in this study amounted to 76 students. The data analysis technique used in this study uses SmartPLS version 4.0 software. Furthermore, the data analysis techniques that researchers use in this study consist of outer model analysis, inner model analysis, and direct effect hypothesis testing. The results of the study indicate that there is a positive and significant direct effect together between Internships and Work Motivation on student' Work readiness.

Keywords: Internship; Work Motivation; Students' Work Readiness.

ABSTRAK

Kesiapan kerja merupakan salah satu modal utama yang harus dimiliki mahasiswa sebelum terjun ke dunia kerja. Tujuan dari penelitian ini adalah untuk mengetahui Pengaruh Magang dan Motivasi Kerja Terhadap Kesiapan Kerja Mahasiswa Rumpun Prodi Pendidikan Ekonomi dan Administrasi Universitas Negeri Jakarta. Metode penelitian yang peneliti gunakan pada penelitian ini adalah metode survei dengan pendekatan kuantitatif. Populasi pada penelitian ini adalah seluruh mahasiswa aktif Rumpun Prodi Ekonomi dan Administrasi Universitas Negeri Jakarta sebanyak 1.634 mahasiswa dan populasi terjangkau sebanyak 318 mahasiswa. Teknik pengambilan sampel menggunakan *proportionate stratified random sampling* menggunakan rumus Slovin dengan *margin of error* sebesar 10% sehingga sampel dalam penelitian ini berjumlah 76 mahasiswa. Teknik analisis data yang digunakan pada penelitian ini menggunakan perangkat lunak *SmartPLS* versi 4.0. Selanjutnya untuk teknik analisis data yang peneliti gunakan pada penelitian ini terdiri dari analisis *outer model*, analisis *inner model*, dan pengujian hipotesis pengaruh langsung. Hasil dari penelitian menunjukkan bahwa terdapat pengaruh langsung yang positif dan signifikan secara bersama-sama antara Magang dan Motivasi Kerja Terhadap Kesiapan Kerja mahasiswa.

Kata Kunci: Magang; Motivasi Kerja; Kesiapan Kerja Mahasiswa.

INTRODUCTION

Student work readiness is closely related to the level of quality of human resources, universities have a strategic role in creating superior and innovative humans for the sake of increasing national competitiveness, which will then be followed by an increase in general welfare and of course will also have a positive impact on the progress of the national economy. Not stopping there, universities also play a role in forming a skilled and expert workforce that is ready to enter the world of work.

Based on data from the United Nations Agency for Development, in 2022 Indonesia's Human Development Index score is 0.75. The score is ranked 114th out of 191 countries in the world. This shows that the quality of Indonesia's human resources is still relatively low. If the problem of the low quality of human resources is not resolved in the future, Indonesia's demographic bonus, which should be enjoyed as one of the national advantages, will instead become a burden for the continuity of the life of the nation and state, because it shows that our competitiveness is still far behind many other countries in the world.

According to Moh. Tayeb in (Wibowo & Rahmadi, 2020) work readiness is a series of behaviors related to the process of identifying, planning, determining, and implementing certain work goals for an individual in accordance with the stages and development of his age. The factors that influence work readiness according to (Amri et al., 2022) and Sukardi in (Wulandari & Dian, 2017) are as follows; From internal factors, namely a factor that comes from within, including; physical and mental maturity, pressure, creativity, interest, talent, intelligence, independence, mastery of science, and motivation. Then there are also external factors including; the role of society, family, school facilities and infrastructure, information about the world of work, and work practice / internship activities where these factors come from outside themselves. The same thing was also stated by Achmad in (Muspawi & Lestari, 2020) stating that work readiness is influenced by the following factors: motivation, work practice activities, vocational guidance, parents' economy, students' learning achievements, information related to the world of work, and expectations of future work.

Unfortunately, based on data released by Sakernas (National Labor Force Survey), it shows that in August 2022 there were still many university graduates who entered the status of open unemployment in Indonesia, which amounted to 7.9% or around 673 thousand people from the total national open unemployment rate. This number is even higher than the number of open unemployment from the level of not/not yet graduated from elementary school, which is slightly below 663 thousand people. This shows that it is not a guarantee that someone graduating from college will have good work readiness. Therefore, universities often provide internship programs for their students before they graduate from campus. This is certainly done in order to improve the competencies possessed by students so that they are better prepared to enter the world of work. For the definition of internship itself is a form of practical work activities carried out in a relatively short period of time where students are trained and given experience in a particular career field that suits their interests. In addition to internship activities, students must also have good work motivation in order to have the drive to enter the world of work. With good work motivation, students will be eager to further explore their talents and interests to be applied to the world of work. The definition of work motivation is a set of energetic forces that come from within individuals and their environment to initiate work-related behavior and determine its shape, direction, intensity, and duration.

This study aims to determine the effect of internships and work motivation on the work readiness of students in the Economics and Administration Education study program at State University of Jakarta. With this research, researchers hope that this research can contribute to the development of the academic world, especially in terms of preparing students to be able to have good work readiness before entering the world of work. Therefore, the researcher has

made a conceptual framework so that readers can better understand the flow of this research, the following explanation:

Figure 1. Conceptual Framework

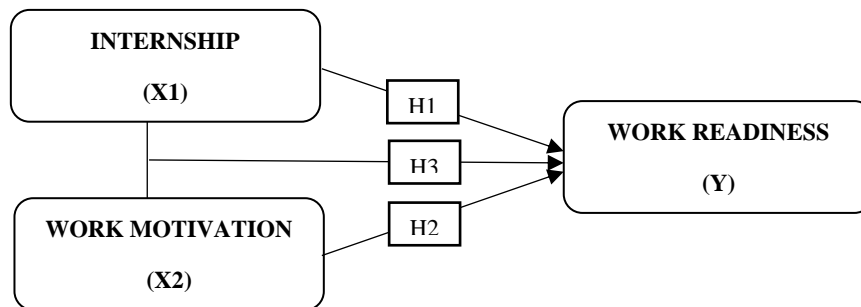

Source: Data processed by researcher (2023)

LITERATURE REVIEW

Work Readiness

Work readiness is an important thing that must be possessed by a student, especially those who are in the final stages of college. According to Firdaus in (Dahlan & Pandeyan, 2021), work readiness is the willingness to take responsibility accompanied by the ability to exert all individual behavior in the workplace. Then according to Kartini in (Wibowo & Rahmadi, 2020), work readiness is a person's ability to carry out work both inside and outside of work relations in order to produce goods or services. Meanwhile, Herminanto Sofyan in (Wibowo & Rahmadi, 2020), argues that work readiness is a person's ability to complete a certain job, without experiencing difficulties and obstacles with good results.

In line with the above opinion according to Gunawan in (Setiarini et al., 2022), work readiness is important for the industrial world or the world of work to become a professional middle-level workforce and be able to work in accordance with their field of expertise. Then according to Yulianti and Khafid (Setiarini et al., 2022), work readiness is a description of the set of skills possessed by an individual, if the level of skill is high, the higher the level of work readiness. It applies vice versa, the lower the skills, the lower the level of work readiness.

As explained by Fitriyanto (Rahmawati et al., 2019), put forward the theory that several indicators that influence work readiness include: having logical and objective considerations, having a critical attitude, being able to adapt to the environment, having the ambition to progress, and having the ability to work together.

According to (Muspawi & Lestari, 2020) the factors of work readiness include the following: motivation, work practice / internship, vocational guidance, parents' economy, students' learning achievements, information related to the world of work, and future job expectations. In line with this opinion, according to (Amri et al., 2022) the factors that influence work readiness include: 1.) Internal factors: physical and mental maturity, pressure, creativity, interest, talent, intelligence, independence, mastery of science, and motivation. 2.) External factors: the role of society, family, school facilities and infrastructure, information about the world of work, and work / internship activities.

Internship

According to Badeni in (Rochmayanti et al., 2021), apprenticeship itself is one part of dual system education which is a development of the vocational education system. The aim is to facilitate the search for the availability of expertise with the demand for certain specific skills from institutions that need workers, especially from institutions that prioritize the quality of labor. In line with these understandings, according to Setyadi in (Supriyanto et al., 2022), internship work practice is an external factor that influences student work readiness, where internship work practice will be a forum for students to try to enter the field according to their field.

Then based on sources from books, according to (Firdaus & Chairunisa, 2021), argues in his book that internship is a form of workplace learning that provides opportunities for students to experience how to become an employee who aims to develop the competencies they have in field work within a certain period of time accompanied by a figure who is an expert in the work being studied in the internship practice. Furthermore, according to (Muhammad Yusril Helmi Setyawan, 2020), in his book states that internship is a learning process while working and interns will get direction and guidance from seniors in the place where they work on a job to be carried out.

Some indicators of internship according to Kim and Rogers in (Fauzan et al., 2023), namely, gaining an understanding of work knowledge, gaining skills, there is a match between skills and industry needs, and getting direction from mentors in the workplace.

Work Motivation

According to Uno (Setiarini et al., 2022), work motivation is the spirit that arises so as to create the urge to work. This motivation arises because of the desire to carry out activities, then driven by the need for activity, there are goals and hopes to be achieved, as a tribute to oneself, spurred by the positive spirit of the environment and the existence of interesting things to be used as routine activities. According to (Prof. Dr. H. Mukhtar et al., 2023), work motivation is a person's willingness to want to do his job well. If an individual does not have good self-motivation in carrying out the work that is his responsibility, the individual will not have enthusiasm in carrying out his work.

In other sources, several similar opinions were found, namely according to Sondang P. Siagian (Supriyadi et al., n.d.), work motivation provides encouragement for a person so that he is willing to exert all his abilities in growing his skills and knowledge along with his energy and time in order to carry out the work that is his obligation with the aim of achieving a predetermined target. Then according to (Effendi et al., 2022), work motivation is an impulse that influences labor behavior, to try to increase work productivity because of the belief that increased productivity has benefits for the continuity of his career at work.

Indicators that influence work motivation according to (Usman & Suherman, 2020) include: personal interests, there is an urge to develop, have hopes and ideals, and there is encouragement from the environment.

RESEARCH METHODS

This research uses a quantitative approach as its research method and uses the survey method in its data collection techniques. The concept of quantitative research basically sets its focus on analyzing and collecting numerical data. Quantitative research is usually taken to provide an average picture that can be described in the form of patterns, cause-and-effect relationships, the influence of certain variables, and so on (Sukmawati et al., 2023). In the survey method, data collection is carried out through filling out a questionnaire or questionnaire filled out by respondents who represent a sample of a certain population (Dr. Drs. Bambang

Sudaryana & Dr. H. R. Ricky Agusiady, 2022), which in this case are students of the Economics and Administration Education Study Program at State University Jakarta. So that this research will use primary data, namely data obtained through a questionnaire which the researcher will distribute through the help of google form to 76 sample respondents using proportionate stratified random sampling technique from the total affordable population of 318 students for further processing of these data using SmartPLS software version 4.0. Then in the questionnaire the researcher provides 5 alternative answers as options that can be selected by respondents using a likert scale. This study aims to test the hypothesis regarding the effect of Internship (X1) and Work Motivation (X2) on Work Readiness (Y).

RESULT AND DISCUSSION

Research Results

A. Measurement Model Analysis (Outer Model)

1) Convergent Validity

In measuring discriminant validity, there is a requirement that different constructs do not have a strong correlation characterized by a score <0.9 . The way to find out is to test it using reflective indicators. Besides that, there are three other calculations that are also carried out to strengthen the results of the discriminant validity test, namely the calculation of HTMT, Fornell Larcker, and cross loading.

Table 1. Outer Loading Results After Calculation

	Internship (X1)	Work Motivation (X2)	Work Readiness (Y)
X1.3	0.803		
X1.6	0.741		
X1.9	0.755		
X1.12	0.739		
X2.3		0.811	
X2.6		0.763	
X2.9		0.792	
X2.12		0.745	
Y3			0.798
Y6			0.718
Y9			0.781
Y12			0.742
Y15			0.746

Source: Data processed by researcher (2023)

Through the Cronbach's alpha table above, it can be seen that all variables in this study obtained a Cronbach's alpha score above 0.7. So that researchers can conclude that all variables in this study are valid.

2) Discriminant Validity

In measuring discriminant validity, there is a requirement that different constructs do not have a strong correlation characterized by a score <0.9 . The way to find out is to test it using reflective indicators. Besides that, there are three other calculations that are also carried out to strengthen the results of the discriminant validity test, namely the calculation of HTMT, Fornell Larcker, and cross loading.

Table 2. Discriminant Validity HTMT

	Internship (X1)	Work Motivation (X2)	Work Readiness (Y)
X1			
X2	0.487		
Y	0.618	0.645	

Source: Data processed by researcher (2023)

In the HTMT discriminant validity table above, all pairs of variables scored <0.9, be it variables X1 and X2 (score 0.487), variables X1 and Y (score 0.618), or variables X2 and Y (score 0.645). So that we can conclude that the entire pair of variables does not have a strong correlation and the HTMT discriminant validity results are met.

Table 3. Discriminant Validity Fornell Larcker

	Internship (X1)	Work Motivation (X2)	Work Readiness (Y)
X1	0.760		
X2	0.381	0.778	
Y	0.509	0.541	0.758

Source: Data processed by researcher (2023)

Through the information from the table above, it can be seen that all diagonal axis values are greater than the value of other variables underneath so that the results of discriminant validity fornell larcker are fulfilled.

Table 4. Discriminant Validity Loading Factor

	Internship (X1)	Work Motivation (X2)	Work Readiness (Y)
X1.3	0.803	0.374	0.494
X1.6	0.741	0.393	0.316
X1.9	0.755	0.170	0.318
X1.12	0.739	0.198	0.371
X2.3	0.250	0.811	0.426
X2.6	0.061	0.763	0.450
X2.9	0.282	0.792	0.322
X2.12	0.582	0.745	0.454
Y3	0.472	0.516	0.798
Y6	0.389	0.251	0.718
Y9	0.338	0.422	0.781
Y12	0.394	0.367	0.742
Y15	0.317	0.441	0.746

Source: Data processed by researcher (2023)

In the discriminant validity loading factor table above, it can be seen that each variable indicator, both the independent variable X and the dependent variable Y has a loading factor value that is greater than the loading factor on other variable constructs, marked with green numbers. So that researchers can conclude that the discriminant validity loading factor analysis is fulfilled.



3) Composite Reliability

Composite reliability is used to measure the reliability of a construct with its reflective indicators. Reliability testing is carried out to determine the level of consistency, level of accuracy, and level of precision of an instrument in measuring a research construct. The score that must be met in testing composite reliability or also called construct reliability must be greater than 0.7. Below are the results of the composite reliability index that researchers obtained along with the results of the other two measuring instruments, namely the Cronbach's alpha index and the average variance extracted (AVE) index:

Table 5. Composite Reliability

	<i>Cronbach's Alpha</i>	<i>Composite Reliability</i>	<i>Average Variance Extracted (AVE)</i>
Magang (X1)	0.760	0.845	0.577
Motivasi Kerja (X2)	0.784	0.860	0.606
Kesiapan Kerja (Y)	0.815	0.871	0.574

Source: Data processed by researcher (2023)

In determining whether a research variable is reliable or not, it can be seen from the acquisition of a composite reliability index whose score is > 0.7 and an average variance extracted (AVE) index whose score is > 0.5. In the table above, it can be seen that all variables meet the requirements of convergent validity and can be declared reliable because the acquisition of the composite reliability score of all variables is above 0.7 and the average variance extracted (AVE) score is above 0.5.

B. Structural Model Analysis (Inner Model)

1) R-Square (R^2)

The R^2 value is used to describe the variance of an exogenous variable on the endogenous variable it affects, whether it has a substantive effect or not. In addition, it is also able to explain the magnitude of the ratio of dependent latent variables that can be defined by independent latent variables. Some criteria for the variation are: strong (R^2 value = 0.67), moderate (R^2 value = 0.33), and weak (R^2 value = 0.19). The R^2 results obtained in this study are as follows:

Table 6. R-Square

	<i>R-Square</i>	<i>R-Square Adjusted</i>	<i>Description</i>
Kesiapan Kerja (Y)	0.400	0.383	Moderate

Source: Data processed by researcher (2023)

Through the information in the table above, it can be seen that the amount of R^2 value on the Work Readiness Y variable is 0.400 so that researchers can conclude that there is an influence of 40.0% between the X1 Internship variable and the X2 Work Motivation variable on the Y Work Readiness variable. For a higher level of accuracy, it can be seen in the score of the Adjusted R^2 value on the Work Readiness variable of 0.383 so that researchers can conclude that there is at least a 38.3% influence between the X1 Internship variable and the X2 Work Motivation variable on the Y Work Readiness variable.

2) F-Square (F^2)

The F^2 procedure is carried out to determine changes in the R^2 value of an endogenous construct and can provide an overview of the relative impact of an independent variable on its dependent variable. Effect Size or F^2 value is classified into three criteria, namely: small category (F^2 value = 0.02), moderate category (F^2 value = 0.15), and large category (F^2 value = 0.35). The F^2 results obtained in this study are as follows:

Table 8. F-Square

	Internship (X1)	Work Motivation (X2)	Work Readiness (Y)
Magang X1			0.178
Motivasi Kerja (X2)			0.234
Kesiapan Kerja (Y)			

Source: Data processed by researcher (2023)

Through the information in the table above, it can be seen that the effect of the X1 Internship variable construct with the Y Work Readiness variable construct is 0.178, thus the two variables have a moderate relationship. Meanwhile, the effect between the construct of the X2 Work Motivation variable and the construct of the Y Work Readiness variable has a value of 0.234, thus the two variables have a moderate relationship as well.

C. Hypothesis Test

Table 9. Hypothesis Test by Bootstrapping

	Original Sample (O)	Sample Mean (M)	Standard Deviation (STDEV)	T-Statistics (O/STDEV)	P-Values
Internship -> Work Readiness	0.354	0.364	0.094	3.771	0.000
Work Motivation -> Work Readiness	0.406	0.416	0.105	3.854	0.000

Source: Data processed by researcher (2023)

H1 : The Effect of Internship on Work Readiness

Through the results of the calculation of path coefficients in the bootstrapping hypothesis test table, the Original Sample value of 0.354 is obtained from the Internship variable (X1) on the Work Readiness variable (Y), then for the T-Statistics value of $3.771 > 1.96$ and for the P-Value of $0.000 < 0.05$. So that researchers can conclude that the first hypothesis which states that the Internship variable has a positive and significant effect on the Work Readiness of Students of the Economics and Administration Education Study Program at State University of Jakarta is accepted.

H2 : The Effect of Work Motivation on Work Readiness

Through the results of the calculation of path coefficients in the bootstrapping hypothesis test table, an Original Sample value of 0.406 is obtained from the Work Motivation variable (X2) on the Work Readiness variable (Y), then for the T-Statistics value of $3.854 > 1.96$ and for the P-Value of $0.000 < 0.05$. So that researchers can conclude that the second hypothesis which states that the Work Motivation variable has a positive and significant effect

on the Work Readiness of Students of the Economics and Administration Education Study Program at State University of Jakarta is also accepted.

H3 : The Effect of Internships and Work Motivation on Work Readiness

Through the results of the calculation of path coefficients in the bootstrapping hypothesis testing table, it is obtained quite satisfactory results that the Internship variable (X1) and the Work Motivation variable (X2) simultaneously have a positive effect on Work Readiness (Y) of Economics and Administration Education Study Program Students of State University of Jakarta. Through the F-Square calculation, a score of 0.178 was obtained from the effect of the Internship variable (X1) on Work Readiness (Y) and a score of 0.234 from the effect of the Work Motivation variable (X2) on Work Readiness (Y). So that researchers can conclude that the Internship variable (X1) and Work Motivation (X2) have a moderate influence on the Work Readiness variable (Y) of Economics and Administration Education Study Program Students at State University Jakarta, so the third hypothesis in this study is also accepted.

Research Discussions

The Effect of Internship on Work Readiness

Through the results of the calculation of path coefficients in the bootstrapping hypothesis test table, the Original Sample value of 0.354 is obtained from the Internship variable (X1) on the Work Readiness variable (Y), then for the T-Statistics value of $3.771 > 1.96$ and for the P-Value of $0.000 < 0.05$. So that researchers can conclude that the first hypothesis which states that the Internship variable has a positive and significant effect on the Work Readiness of Students of the Economics and Administration Education Study Program at State University of Jakarta or H1 is accepted.

This is in accordance with research conducted by (Kapareliotis et al., 2019) conducted in various schools in Greece which shows that internships through job prospects have an effect on work readiness. Students who take part in the internship program positively assess all aspects of the work readiness construct. They know what employers expect them to do in the workplace. Relevant results can also be found in research conducted by (Rumonim et al., 2019) which shows that field work practice or internships have an effect on work readiness because students who have participated in work practice or internship programs are effectively able to apply their basic academic skills in the workplace. Then the same results were also found in research (Muhammad & Mustari, 2021) using the multiple linear regression test method which states that internships have a positive and significant effect on the work readiness of students of the Faculty of Economics and Business, Universitas Brawijaya.

The Effect of Work Motivation on Work Readiness

Through the results of the calculation of path coefficients in the bootstrapping hypothesis test table, an Original Sample value of 0.406 is obtained from the Work Motivation variable (X2) on the Work Readiness variable (Y), then for the T-Statistics value of $3.854 > 1.96$ and for the P-Value of $0.000 < 0.05$. So that researchers can conclude that the second hypothesis which states that the Work Motivation variable has a positive and significant effect on the Work Readiness of Students of the Economics and Administration Education Study Program at State University of Jakarta or H2 is also accepted.

These results are in accordance with research conducted by (Deswarta et al., 2023) found that work motivation derived from the role of the family environment can provide encouragement for students to achieve their goals so that it can have a significant effect and is classified as quite good in its influence on student work readiness. In line with the research conducted by Deswarta above, relevant results were also found in research (Amri et al., 2022) which showed the results that if the level of work motivation is high, it will also be followed by a high level of work readiness. Then it is also supported by the results of research conducted by (Rochmayanti et al., 2021) which found that students' work readiness is also driven by motivation from within the students themselves. Because with the encouragement of good motivation, someone will make every effort to be able to carry out work seriously. In addition, students' work readiness can also arise from the hopes and aspirations they have to achieve a bright future.

The Effect of Internships and Work Motivation on Work Readiness

Through the results of the calculation of path coefficients in the bootstrapping hypothesis test table, it is obtained quite satisfactory results that the Internship variable (X1) and the Work Motivation variable (X2) simultaneously have a positive effect on Job Readiness (Y) of Economics and Administration Education Study Program Students of State University of Jakarta. Through the F-Square calculation, a score of 0.178 was obtained from the effect of the Internship variable (X1) on Work Readiness (Y) and a score of 0.234 from the effect of the Work Motivation variable (X2) on Work Readiness (Y). Then it can also be seen in the results of the coefficient of determination or R² value on the Work Readiness variable which found a result of 0.400 so that researchers can conclude that there is an influence of 40.0% between the Internship variable and the Work Motivation variable together on the Work Readiness variable while the other 60.0% is influenced by other factors that are outside the model. So that researchers can conclude that the Internship variable (X1) and the Work Motivation variable (X2) have a positive and significant influence at a moderate level on the Work Readiness variable (Y) of Economics and Administration Education Study Program Students at State University of Jakarta, so the third hypothesis or H3 in this study is also accepted.

These results are in line with research conducted by (Khoiroh & Prajanti, 2018) found that the success of the internship program supported by a high level of work motivation will increase student work readiness. This also applies vice versa, if the internship program is considered a failure, it will result in low student work motivation, so the level of work readiness will also decrease. In line with the research above, in research conducted by (Wibowo & Nugroho, 2021) it was found that students who have participated in an internship program tend to have good work motivation than those who have never carried out an internship program so that these two things, namely the internship program and work motivation together, will have a positive impact on increasing student work readiness. Then it is also in line with research conducted by (Fauzan et al., 2023) which shows that there is a positive and significant influence between internships and motivation on student work readiness.

CONCLUSION AND RECOMENDATION

Based on the results of this study on the topic of the Effect of Internships and Work Motivation on the Work Readiness of Students of the Economics and Administration Education Study Program at State University of Jakarta, it was found that:

First hypothesis, there is a positive and significant direct effect of Internship on Student Work Readiness with an original sample value of 0.354 and t-statistic of $3.771 > 1.96$ and p-value of $0.000 < 0.05$, so that if the effect of internship is high, the higher the level of work readiness of students to be able to enter the world of work, and this applies vice versa. If the influence of internship is low, it will also have an impact on the low level of work readiness of students.

Second hypothesis, there is a positive and significant direct effect of Work Motivation on Student Work Readiness with an original sample value of 0.406 and t-statistic of $3.854 > 1.96$ and p-value of $0.000 < 0.05$, so that if students have high work motivation, their level of work readiness will also be higher than those who have a low level of work motivation. The same positive relationship also applies if the level of student work motivation is low, then it also has an impact on the low level of student work readiness.

Third hypothesis, there is a simultaneous positive and significant direct influence between Internship and Work Motivation on the Work Readiness of Students of the Economics and Administration Study Program at State University of Jakarta with an F^2 score of 0.178 from the effect of the Internship variable (X1) on Work Readiness (Y) and a score of 0.234 from the effect of the Work Motivation variable (X2) on Work Readiness (Y). Then it can also be seen in the results of the coefficient of determination or R^2 value on the Work Readiness variable which found a result of 0.400 so that researchers can conclude that there is a moderate level of influence of 40.0% between the Internship variable and the Work Motivation variable together on the Work Readiness variable, so it can be concluded that the higher the influence of internships and work motivation, the higher the level of student work readiness.

Suggestions for the clump of Economics and Administration Education study programs at the State University of Jakarta, so that more programs can help improve student work skills, especially in the implementation of internship activities and maybe also in the form of seminars on the latest developments in the world of work. So that later it is hoped that students can have high work motivation and of course it will have an impact on the high level of student work readiness. This will certainly be very useful for forming a work-ready young generation so that it will reduce the risk of unemployment after graduating from university as a phenomenon that still occurs today in various universities in Indonesia.

Suggestions for students, students are expected to further improve their work readiness by being proactive in participating in various campus activities that can foster their work skills such as internships or other activities in the form of seminars, job training or other organizational activities. Then to foster their work motivation, students can also consult with lecturers or their parents regarding the jobs they want to achieve in the future. Because in the process, if students are diligent and active in doing things like this, gradually of course the level of work readiness in themselves will also increase so that they become a generation that is ready to enter the world of work.

Suggestions for future research, researchers recommend that other variables or factors that might influence work readiness be added, so that they can strengthen and expand the new research to be more varied and comprehensive than this study. Then in future studies can also

be expanded sample and population coverage or can even use other research methods that are different from this study so that they can provide more in-depth and accurate results.

REFERENCES

- Amri, R., Irwanto, I., & Aribowo, D. (2022). Pengaruh Motivasi Kerja dan Kesesuaian Kompetensi Praktik Kerja Lapangan (PKL) terhadap Kesiapan Kerja Siswa SMKN 1 Cinangka. *Reslaj: Religion Education Social Laa Roiba Journal*, 4(3), 752–764. <https://doi.org/10.47467/reslaj.v4i3.863>
- Dahlan, U. A., & Pandeyan, J. P. (2021). *Effect of internship performance and work motivation on vocational students' work readiness*. 2(2), 45–52. <https://doi.org/10.12928/ijei.v2i2.5553>
- Deswarta, D., Mardianty, D., & Bowo, B. (2023). Pengaruh Soft Skill, Hard Skill Dan Motivasi Kerja Terhadap Kesiapan Kerja Mahasiswa Fakultas Ekonomi Dan Bisnis Universitas Islam Riau Dimasa Endemi Covid 19. *Management Studies and Entrepreneurship Journal (MSEJ)*, 4(1), 364–372.
- Dr. Drs. Bambang Sudaryana, D. E. A. M. S. M. A. C. I. E. A., & Dr. H. R. Ricky Agusiady, S. E. M. M. A. C. F. A. (2022). *Metodologi Penelitian Kuantitatif*. Deepublish. <https://books.google.co.id/books?id=oKdgEAAAQBAJ>
- Editor. (2022). *Negara dengan Indeks Pembangunan Manusia (IPM) Terbaik 2022*. GoodStats. <https://goodstats.id/infographic/negara-dengan-indeks-pembangunan-manusia-ipm-terbaik-2022-2BNWK>
- Fauzan, A., Triyono, M. B., Hardiyanta, R. A. P., Daryono, R. W., & Arifah, S. (2023). The Effect of Internship and Work Motivation on Students' Work Readiness in Vocational Education: PLS-SEM Approach. *Journal of Innovation in Educational and Cultural Research*, 4(1), 26–34.
- Firdaus, M., & Chairunisa, F. (2021). *Belajar Sambil Bekerja Dan Bekerja Sambil Belajar*. Deepublish. <https://books.google.co.id/books?id=IRs3EAAAQBAJ>
- Kapareliotis, I., Voutsina, K., & Patsiotis, A. (2019). Internship and employability prospects: assessing student's work readiness. *Higher Education, Skills and Work-Based Learning*, 9(4), 538–549. <https://doi.org/10.1108/HESWBL-08-2018-0086>
- Khoiroh, M., & Prajanti, S. D. W. (2018). Pengaruh Motivasi Kerja, Praktik Kerja Industri, Penguasaan Soft Skill, Dan Informasi Dunia Kerja Terhadap Kesiapan Kerja Siswa Smk. *Economic Education Analysis Journal*, 7(3), 1010–1024.
- Kusnandar, V. B. (2023). *Ada 673 Ribu Pengangguran Lulusan Universitas pada Agustus 2022*. Databoks. <https://databoks.katadata.co.id/datapublish/2023/01/10/ada-673-ribu-pengangguran-lulusan-universitas-pada-agustus-2022>
- Muhammad, A., & Mustari, I. (2021). TERHADAP KESIAPAN KERJA (Studi pada Mahasiswa Fakultas Ekonomi Dan Bisnis Universitas Brawijaya) Supervisor : *Jimfeb (Jurnal Ilmiah Mahasiswa FEB)*, 1, 1–18.
- Muhammad Yusril Helmi Setyawan, A. S. M. (2020). *Panduan Lengkap Membangun Sistem Monitoring Kinerja Mahasiswa Internship Berbasis Web Dan Global Positioning System*. Kreatif Industri Nusantara. <https://books.google.co.id/books?id=wqLzDwAAQBAJ>
- Muspawi, M., & Lestari, A. (2020). Membangun Kesiapan Kerja Calon Tenaga Kerja. *Jurnal Literasiologi*, 4(1), 111–117. <https://doi.org/10.47783/literasiologi.v4i1.138>
- Rahmawati, D. U., Muhtar, & Jaryanto. (2019). Hubungan Prestasi Belajar Kognitif Akuntansi dan Pengala-man Praktik Kerja Industri dengan Kesiapan Kerja Siswa Kelas XII Akuntansi SMK. *Tata Arta" UNS*, 5(3), 83–96.

- Rochmayanti, F., Kuat, T., & Tentama, F. (2021). Effect of internship performance and work motivation on vocational students' work readiness. *International Journal on Education Insight*, 2(2), 45–52.
- Rumonim, A., Rantetampang, A. L., Msen, Y., & Mallongi, A. (2019). The Effect of Learning Quality , Field Work Practice and Teaching Quality on the Work Readiness of Jayapura Health Vocational School. *Galore International Journal of Applied Sciences and Humanities*, 3(March), 35–42.
- Setiarini, H., Prabowo, H., Sutrisno, S., & Gultom, H. C. (2022). Pengaruh Soft Skill Dan Pengalaman Magang Kerja Terhadap Kesiapan Kerja Mahasiswa Melalui Motivasi Kerja Sebagai Variabel Intervening (Studi Kasus Pada Mahasiswa Feb Universitas Pgrri Semarang). *EKOBIS: Jurnal Ilmu Manajemen Dan Akuntansi*, 10(2), 195–204.
- Sukmawati, A., Rusmayadi, G., Amalia, M. M., Hikmah, H., Rumata, N. A., P, M. A. C., Abdullah, A., Sari, A., Hulu, D., & Wikaningtyas, R. (2023). *METODE PENELITIAN KUANTITATIF : Teori dan Penerapan Praktis Analisis Data berbasis Studi Kasus*. PT. Sonpedia Publishing Indonesia.
<https://books.google.co.id/books?id=KU3MEAAAQBAJ>
- Supriyanto, S., Munadi, S., Daryono, R. W., Tuah, Y. A. E., Nurtanto, M., & Arifah, S. (2022). The Influence of Internship Experience and Work Motivation on Work Readiness in Vocational Students: PLS-SEM Analysis. *Indonesian Journal on Learning and Advanced Education (IJOLAE)*, 5(1), 32–44.
- Wibowo, A., & Nugroho, B. S. (2021). Pengaruh Motivasi Kerja Dan Praktik Kerja Lapangan Terhadap Kesiapan Kerja Mahasiswa Stmik Sinar Nusantara Surakarta. *Jurnal Ilmiah Edunomika*, 5(02), 881. <https://doi.org/10.29040/jie.v5i2.2695>
- Wibowo, A., & Rahmadi, D. (2020). *Best Score Psikotes Kerja*. Genta Smart Publisher.
<https://books.google.co.id/books?id=SjP4DwAAQBAJ>
- Wulandari, A. K., & Dian, S. (2017). Pengaruh praktik kerja lapangan, bimbingan karir, dan motivasi kerja terhadap kesiapan kerja siswa kelas XII SMK Negeri 1 Karanganyar di Kabupaten Kebumen. *Economic Education Analysis Journal*, 6(1), 131–139.